

BWT bestprotect



The protectors

Water with the protection factor for catering and vending

With BWT bestprotect, you can optimize raw water for catering application in a targeted way. This filter system ensures balanced mineralization and a consistently high pH value in the filtrate – key factors that minimize the risk of corrosion. Hardness-forming calcium ions are safely reduced and deposits of limescale and gypsum prevented in the case of raw water containing carbonates or sulphates. Insoluble or difficult-to-remove deposits in machines are now a thing of the past.

The filter system consists of a filter cartridge with a BWT besthead filter head. Check valves in the filter head prevent water backflow and uncontrolled water discharge. BWT bestprotect food-safe filter systems are pressure-resistant and safe. They can be used worldwide in any drinking water system.

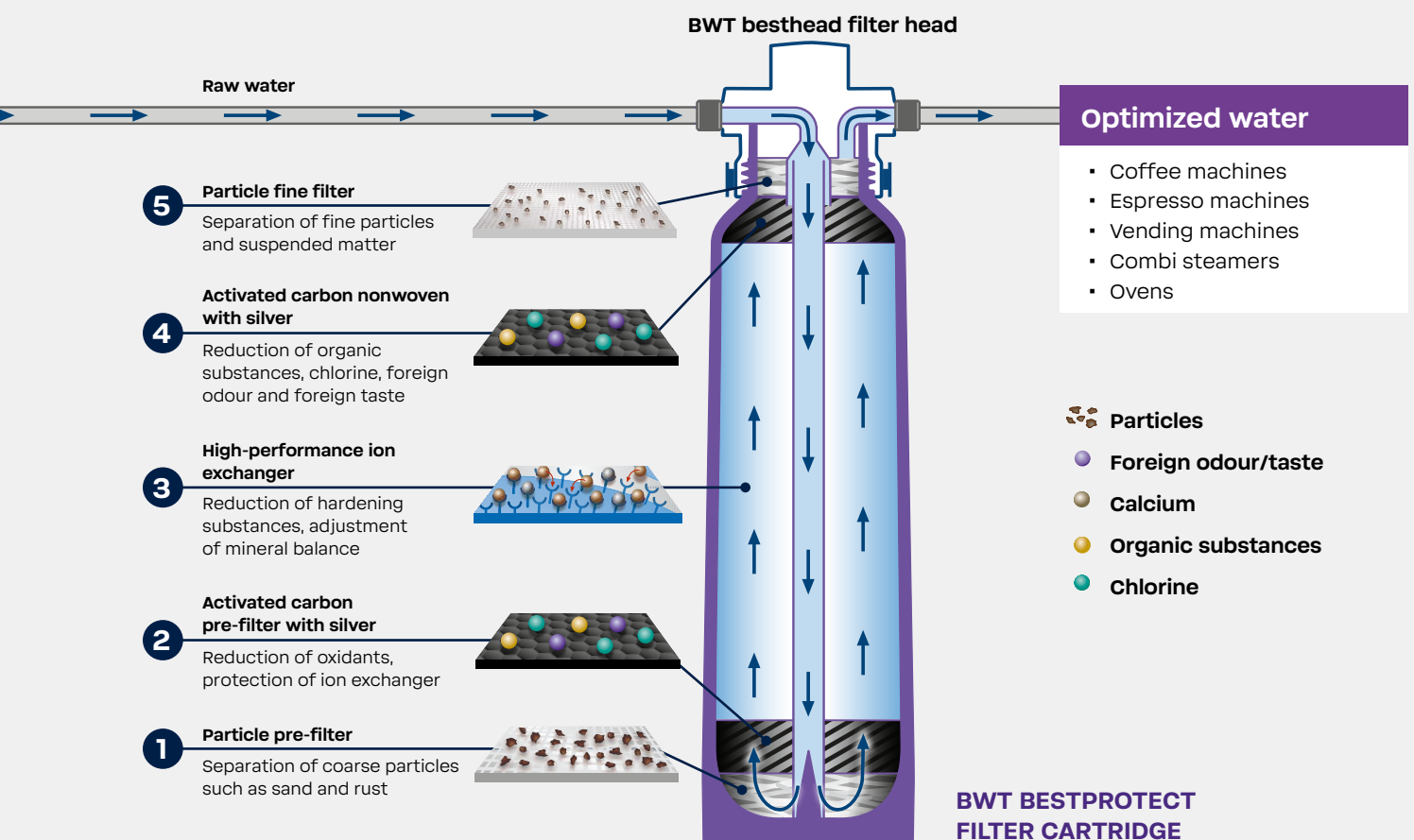

TECHNICAL DATA

| Filter size | S | V | M | XL | 2XL |
|--|-------------------|-------------------|------------------|-------------------|-------------------|
| Total height without bracket (A) in mm | 368 | 429 | 485 | 512 | 576 |
| Connection height (B) in mm | 307 | 368 | 424 | 451 | 515 |
| Ø filter cartridge (C) in mm | 88 | 110 | 130 | 147 | 185 |
| Weight in kg (dry/wet) | 0.9/1.5 | 2.1/3.2 | 2.8/4.2 | 3.8/6.0 | 7.5/11.0 |
| Filter change after month | after 6 or 12* | | | | |
| Order no. for filter cartridge | FS22N00A00 | FS23N00A00 | 125501405 | FS28N00A00 | FS30N00A00 |

* Recommendation: Replace the filter cartridges regularly after 6 months, but at the latest after 12 months or when the filter capacity is reached.

SETTINGS AND CAPACITIES/L⁽¹⁾ (no bypass setting)

| Hot beverage preparation with steam generation / Combination steamer/oven | | | | | |
|---|------------|-------------|-------------|-------------|-------------|
| German total hardness | Size | | | | |
| | S | V | M | XL | 2XL |
| ≤7 | ≥855 | ≥2140 | ≥3143 | ≥5125 | ≥8570 |
| 8 | 750 | 1875 | 2750 | 4458 | 7500 |
| 10 | 600 | 1500 | 2200 | 3590 | 6000 |
| 12 | 505 | 1250 | 1833 | 2620 | 5000 |
| 14 | 440 | 1070 | 1570 | 2245 | 4285 |
| 17 | 380 | 880 | 1294 | 1850 | 3525 |
| 20 | 310 | 750 | 1100 | 1570 | 3000 |
| 23 | 240 | 600 | 957 | 1175 | 2400 |
| ≥25 | ≤225 | ≤556 | ≤880 | ≤1090 | ≤2220 |

⁽¹⁾ Capacities may deviate by up to ±5 % depending on the local water quality and volume flow. Please refer to the operating and installation instructions for more detailed capacity figures. Subject to change.

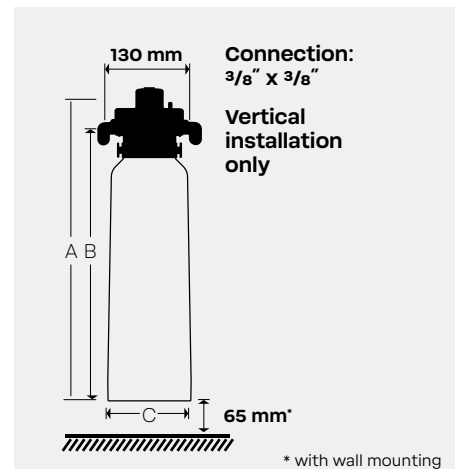

Operating conditions

Input pressure: 2 – 8 bar
 Water temperature: 4 – 30 °C
 Ambient temperature: 4 – 40 °C

ACCESSORIES

| | Description | Order number |
|-------------------------------|--|--------------|
| BWT besthead FLEX filter head | BWT besthead FLEX with 2 connectors 90° elbow, FLEX Insert, M 3/8" made from GFP | FS00Z20A00 |
| BWT besthead FLEX Set 1 | BWT besthead FLEX with 2 connectors 90° elbow, FLEX Insert, M 3/8" made from GFP, Connection hose DN 8, 1.5 m, with ball valve, FLEX Insert 90° elbow made from GFP, cap nut FM 3/8", Connector straight, FLEX Insert x M 3/8" made from GFP, Reduction FM 3/4" x M 3/8" made from GFP | FS00Z39A00 |



MANUFACTURER: SALES:

BWT Holding GmbH:
 Walter-Simmer-Str. 4
 5310 Mondsee, Austria
 bwt-wam.com

**BWT water+more
 Deutschland GmbH:**
 info@water-and-more.de
 Tel.: +49 611 58019-0